

OCTOBER & NOVEMBER 2016 | 5.10 & 5.11

de Stolfe Journal *Candid*





Journal Contents



October & November 2016 | 5.10 & 5.11

3	Candid Comments from the Producer	16	Historical Archives
3	Word for Life	17	Many Mile Markers
4-6	Saddle Break Notes	18-19	100 Years of Beauty
7	Cooking with RG	20	Lubbock's Carpenter Gothic
8-10	Ranching & Farming: Cotton (part 2)	21-26	100 Years of Home Innovation
11	Cotton Club	27	Horse Judging Notes
12-13	Wind Turbines	28	Word Search Answers
14	Pumpkin? Pie. FRAUD!	29	Public Art of Texas Tech University
15	Perfectly Timed Cat Photos	29	Coming in the Next Issue



Candid Comments from the Producer



Ch-ch-ch-changes...

Whereas most of my issues this year were stupidly late, this issue is almost the most on time out of this year! Well, okay, whatever. I was going to do separate issues for October and November, but it didn't happen, so I just combined them. I still plan to have December as a separate issue.

We are nearing the end of the year again and will soon be looking forward to a new year and new hopes and many new changes, with both me personally and in the country. No doubt that this election year seemed to be the most hostile of all recent elections and no doubt that nearly half of the country might just be bitter about the outcome. Well, eight years ago, it was nearly the same in the opposite direction. The point now is that the election is finished and the clear choice decided the victor for the next president. Whether you are in favor of or opposed to President-elect Trump at this point is inconsequential. What we must do now is be a

civilized society respecting the differences of people's opinions, even if we do not agree with them. When we accuse and blame other people's viewpoints because they don't agree, we tear down the very foundation of how this country exists with free speech, freedom of religion, and right to protect ourselves from hostility. That is when a country will collapse and external forces will violently take it over! Choose to respect yourself by acting civilized and you will find that all of the fears were unjustified.

This issue is full of neat stuff including some continuations and other features similar to what I have included in the past. I hope you like them and hope you enjoy the various topics.

I hope you had a great Thanksgiving and know that I wish you the best Christmas or Hanukkah coming shortly!

On the Cover

Fall brings out amazing produce. In September, October, and November, pumpkins are the staple. This particular variety of pumpkin is called Fairytale and comes in multihued shades.



Contents Page

Another variety of pumpkins that has gained popularity in the past decade are these white ones called Lumina. They add a nice unexpected contrast (I call them ghost pumpkins).



Word for Life

1 Peter 2:13-17 (AMP)

"13 Submit yourselves to [the authority of] every human institution for the sake of the Lord [to honor His name], whether it is to a king as one in a position of power, 14 or to governors as sent by him to bring punishment to those who do wrong, and to praise and encourage those who do right. 15 For it is the will of God that by doing right you may silence (muzzle, gag) the [culpable] ignorance and irresponsible criticisms of foolish people. 16 Live as free people, but do not use your freedom as a cover or pretext for evil, but [use it and live] as bond-servants of God. 17 Show respect for all people [treat them honorably], love the brotherhood [of believers], fear God, honor the king."

After nearly two years of a hostile and contentious election process, we finally come to a close as a country for the new president and various other elected positions at the federal, state, and local levels. We also know that as tight a race as the election was that nearly half of the country's citizens would not be happy with the outcome. This is where we really need to pay attention to that last verse to respect other people, love other believers, respect God (that's what "fear" means), and honor the king, or in this case, the president, both current and president-elect. However the next four years plays forth in its specific details, we must rest assured that God is in control and His will is done on earth as it is in Heaven.

Saddle Break Notes

Leadville Visit

From September 2 to 6 three months ago, I left Lubbock and went to Leadville for a visit. I drove up to Colorado Springs, stayed the night, then went to Leadville the next day. I spent two nights in Leadville, then went back to Colorado Springs for the night, and back to Lubbock the next day. This was Labor day weekend. While in Leadville, I did some work for the Temple Israel Museum as well as for a general visit since it had been about 10 months since I was last there.



This is the finished sign I designed for the Hebrew Cemetery.



Here is the 2016 version of the front garden I planted originally in 2014.

Fall Booth Sales

Two separate times in October and November, I set up a booth to sell my stuff. Unfortunately, in both cases, I didn't really sell anything. But, it did give me something to do and at least an attempt to sell my stuff. I still have my stuff for sale on eBay and Etsy.



My first booth was on Saturday, October 1 at the Pollard Ford Pop-up Shops out in the dealer's parking lot. I didn't sell even \$10 but it did not cost me anything to have the booth.



The other booth was on Saturday, November 12 at the Celebration Christmas Market, which was an annual church bazaar of sorts. They had much less than expected turnout. I sold nothing.

Saddle Break Notes

Black Light Puppet Show

At my church, West Texas at the Barn, we don't celebrate the evil holiday of Halloween. Instead, we overcome evil with good by having a Hallelujah Night to honor God instead of Satan. (And frankly is a whole lot more fun than Halloween!) We start out by having carnival games where the kids can win candy and prizes. All the candy has scripture taped to them. This year, I worked the mini basketball game. After a little over an hour of that, everyone goes into the sanctuary. The stage is covered in black cloth and curtains and all of the features of the puppet show are fluorescent. The teen group puts on the show

and runs it (along with a few adults). The teen group has done these puppet shows now for about 6 or 7 years. Before that for two years, we had another church come and do their black light puppet show that they had. This year's theme was heavily influenced by Finding Nemo and the general story line was overtly Christian with a particular fish trying to find God's treasure. The fish and a few friends (namely a sea turtle, a Bible, and a clam) go on a series of adventures to find the treasure. The bulk of the time are the characters are singing to Christian songs (and not wussy children's songs either!) in between the adventures. Interestingly, many of the decorations were recycled from Vacation Bible School, which also had an undersea theme.

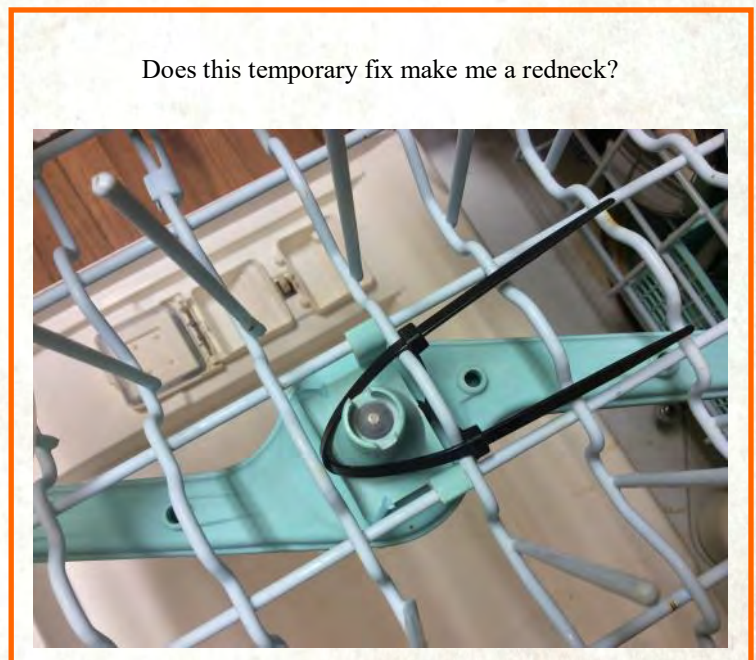
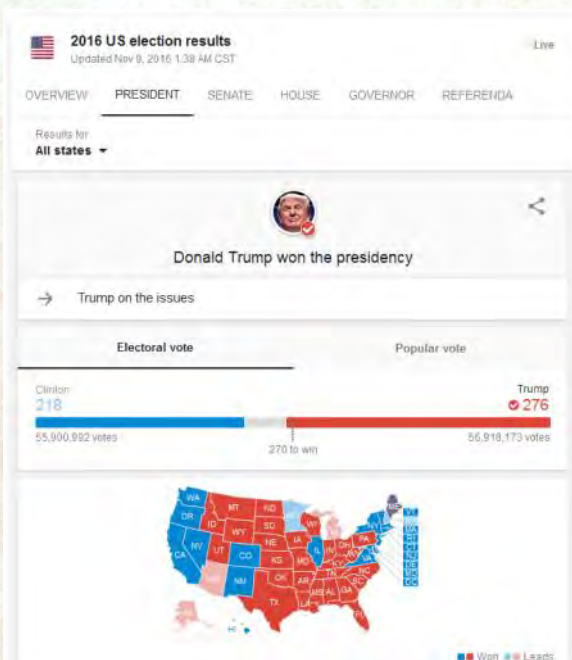

Saddle Break Notes

Colorado Visit

In early September over Labor Day weekend, I went up to Colorado, specifically to go to Leadville. And of course, along the way, I stopped to see and photograph some wonderful vistas! Most of these views I have seen many times before. But they are still nice to look at. Here are a few of them.



That windmill I stop at near Capulin, New Mexico.

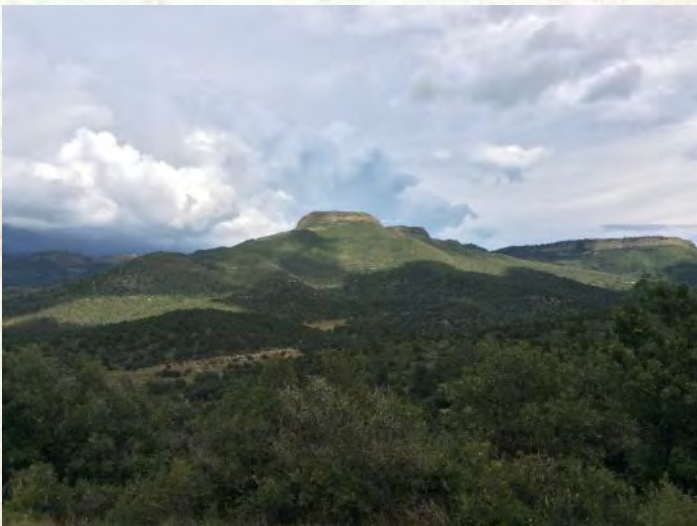

Raton Pass on the Colorado side.



Coming into South Park just past Wilkerson Pass going west.



Some ranch buildings and ranch land in South Park, Colorado



Some ranch buildings and ranch land in South Park, Colorado

Cooking with RG

Cookies



Step 1—Put cookie dough on sheets



Step 2—Bake, then cool (Could have added just a little less flour.)



Step 3—Eat!

Pumpkin Cake



Pumpkin Empanadas



Chicken and Noodles



Ranching and Farming

Cotton Farming in Lubbock and West Texas *(the rest of it)*

In the last issue I included photos of the cotton growing in the fields from most every week since mid June to the end of September. Now, here are photos from the rest of the season through stripping.

Sunday, October 2, 2016



Sunday, October 16, 2016



A note about the two pairs of photos here: The bottom two photos look as if the cotton plants are dying and in fact they are and it is intentional. Before the cotton can be stripped from the plants, the plants are sprayed with defoliant, basically a means to kill the plant and dry up the leaves. Once the plants are dry enough and before the fall rains, the cotton is ready to strip (see the next page). After that, all that is left are the stems called sticks.

Ranching and Farming

Sunday, October 23, 2016



Ranching and Farming



← Sunday, October 30, 2016 →



Sunday, November 6, 2016



Lubbock Cotton Club

“The Lubbock Cotton Club... took its name from the region’s chief agricultural output [cotton]. The original club, located on 50th Street and Railroad Avenue (present-day Southeast Drive) in a renovated Army Quonset hut, opened on November, 11, 1938.”

“The club, established to appeal to Lubbock’s “high society” by hosting well-known orchestras and big bands, flourished. By the mid-1940s the club owners began booking country and western acts. According to former Cotton Club owner, Tommy Hancock, the change in musicians was due to the lack of enough “classy” people in Lubbock to support a 1,400-capacity club.”

“In the mid-1950s the Cotton Club became a hub for rock-and-roll music. Elvis Presley performed at the Cotton Club on numerous occasions in 1955. In attendance at Presley’s performances was a local Lubbock musician, Buddy Holly, who met with Presley and was influenced by his style of music... In 1958 the club burned. Owner Ralph Lowe chose not to rebuild.”

“Tommy Hancock and wife, Charlene Condray Hancock, both well-known musicians in the Lubbock area, asked Ralph Lowe for the club’s sign and for permission to start a new Cotton Club. In 1962 the Hancocks built a new Cotton Club along the Slaton Highway (U.S. Highway 84), about fourteen miles from downtown Lubbock. The Hancocks reopened the Cotton Club, but like its predecessor, it became a victim in 1964 to fire. In 1967, after the new building was complete, the Hancocks reopened the famous dance hall.”

“The late 1960s started a new trend at the Cotton Club. The “hippie generation” emerged in Lubbock and frequented the club. The cowboys, however, also continued to go to the club because Hancock and his band continued to play classic country and western dance music. Surprisingly the cowboys and the alternative crowd got along well...”

“The 1970s saw a continual trend away from country and western music to a more alternative sound. Artists such as Waylon Jennings and the Maines Brothers replaced Bob Wills and Hank Thompson. By 1978 the Hancocks had grown tired of the club business and chose to sell the club to Joe Ely and C.B. Stubblefield. Ely and Stubblefield did not own the club for long, but they were able to book rising artists of the era, such as Stevie Ray Vaughan. In 1982, Ely and Stubblefield chose to close the Cotton Club.”

The building itself is still there and was empty for a while. The building had several attempts as different types of businesses, but is currently empty again.

Musicians performing at either location of the Cotton Club: Adelle Kastle, Frank “Deacon” Murino and his Men about Town, Ray Terry and his Pioneer Playboys, Tex Ritter, Maddox Brothers with Rose, Bob Wills and His Texas Playboys, Hank Thompson, Elvis Presley, Buddy Holly, Little Richard, Fats Domino, Roy Orbison, Waylon Jennings, Maines Brothers, and Stevie Ray Vaughan are the most notable musicians who played at the Cotton Club.

Read more:

<https://tshaonline.org/handbook/online/articles/xdc08>

<http://scottymoore.net/lubbock.html>



The Lubbock Cotton Club located on Slaton Highway, the second location.



Lubbock Cotton Club

In 1938, Clyde Trusty opened a ballroom in a renovated army Quonset hut at this site. The Lubbock Cotton club hosted well-known orchestras and big bands popular at the time. The venue expanded the following year, with room for 1600 people on one of the largest dance floors in West Texas. Bob Wills and His Texas Playboys were among the first Western swing bands to play the cotton club. In 1952, Ralph Lowe brought in national acts including Elvis Presley, who met Buddy Holly during a 1955 show. African American musicians including Charles Brown also played here. In 1958, fire destroyed the club and Lowe sold the business. The Cotton Club continued in a new site until 1980 when it closed for good.” (2008)

Wind Turbines



Basic facts about wind turbines



Some people like them while others loathe them, but they appear to be staying and expanding with great aggressiveness. These are wind turbines. While I shall not attempt to go into the history of them nor the political and like/dislike discussion about them, I will tell you about the descriptive nature of them and give some basic facts about wind turbines. Clearly, the use of wind turbines is a clean renewable source. But despite their benefits, many do not like them for a variety of reasons which I shall not discuss in this article.

The locations of wind turbines are most often in places of regular high winds and locations of updrafts. A wind turbine can only be useful if there is wind! Often called wind farms, you will not usually see a turbine of the size shown to the left alone. They will usually be in clusters and sometimes even hundreds where space is available. If you were to stand under one, you will hear the cyclical whoosh... whoosh... whoosh... whoosh... You must understand that the blades are a large mass cutting through the air and will make a great sound.

- Takes 10 minutes to climb inside the tower to the nacelle.
- To install a turbine, the builders need to dig a hole 100' in diameter and 10' deep which takes a full day. Then another full day just for rebar enforcing, and about 53 concrete trucks for all of the necessary concrete. The concrete takes 2 days to cure.
- A turbine blade is 173' long and weighs about 27k# each. The total diameter of the blade circle is 354'.
- About 8 trucks are needed to deliver all of the parts of the tower, blades, nacelle, and internal components.
- The nacelle is the size of a school bus and weighs 181k#. It contains the generator, gear box, and rotor shaft.
- The tower is about 54' high and weighs nearly 100k#! The bottom has 160 bolts securing the tower to the foundation.
- The total height is 442' and the entire installation takes about three weeks.
- Once installed and working, a wind turbine will pay for itself in about three to four years.

Watch a video of the construction of a MidAmerican Energy wind turbine:

<https://vimeo.com/127520369>

Wind Turbines

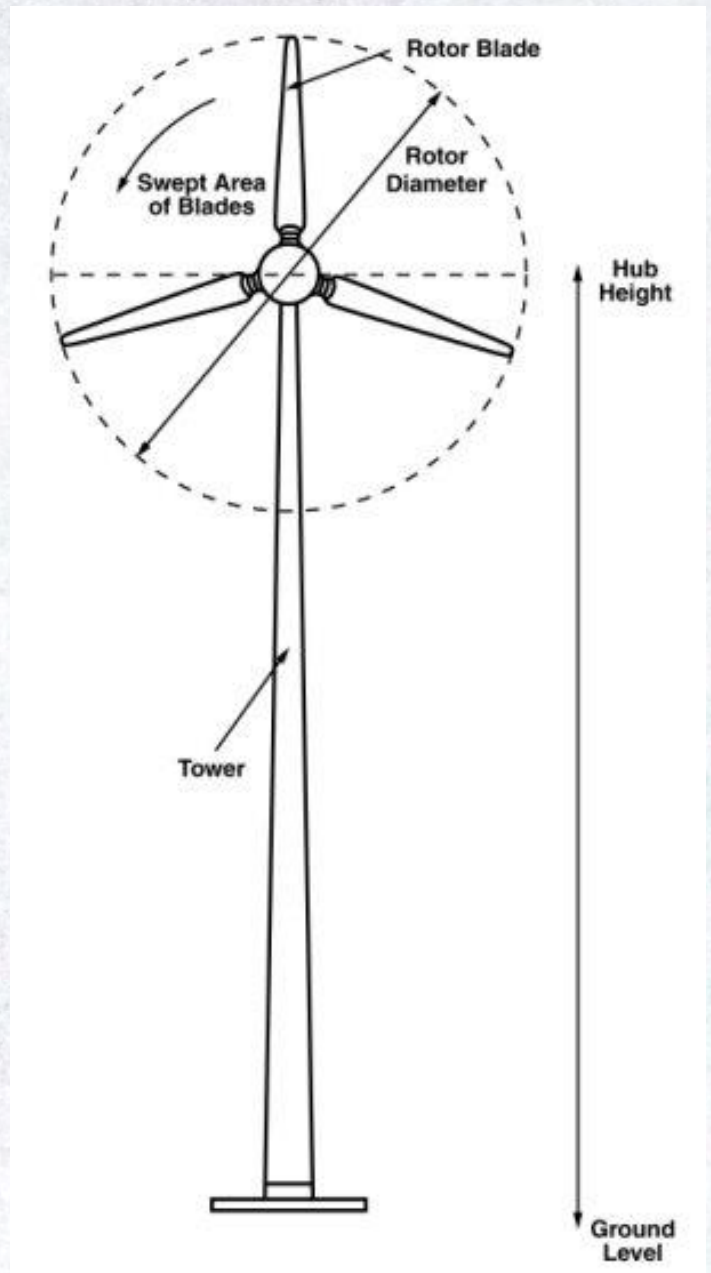
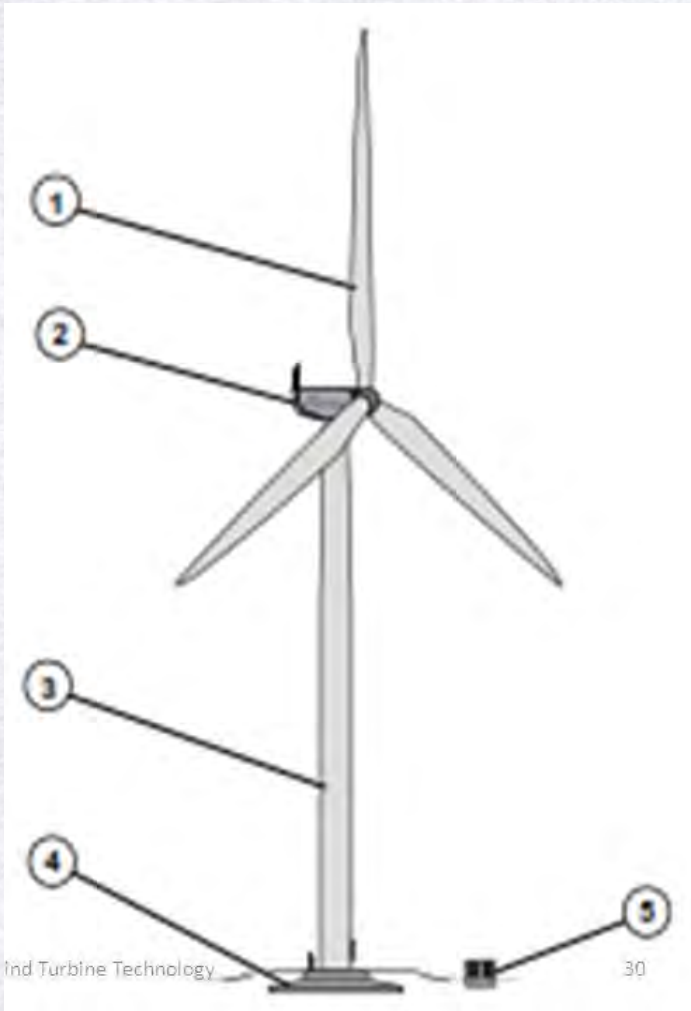

1. Blade (Rotor)
2. Nacelle
3. Tower
4. Foundation
5. Transformer (Substation)

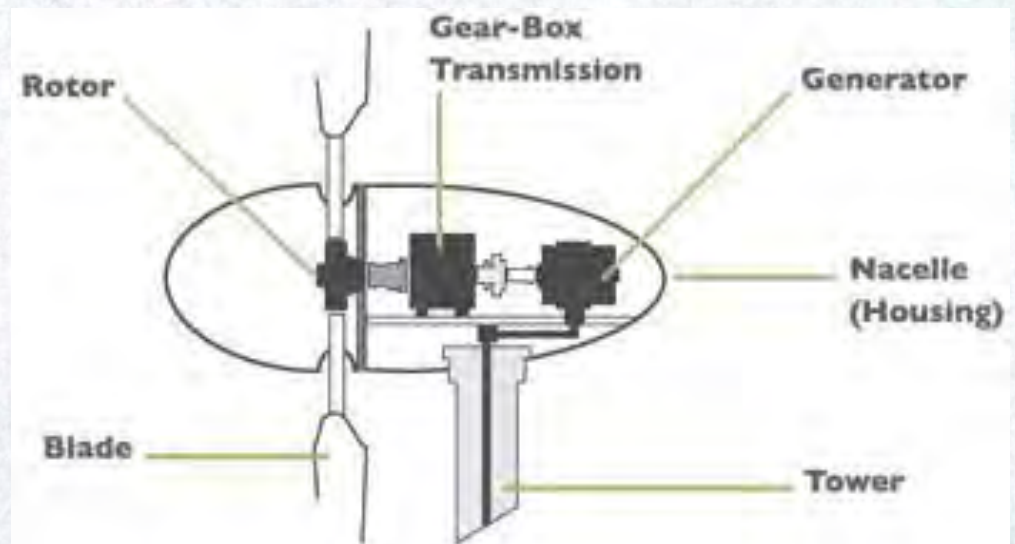



Okay. Well, Sorta...

You know how you go to the store and buy those cans of “100% pure pumpkin” so you can make pies, cakes, bread, cookies, etc? Well, those cans of “pumpkin” puree are sorta not from actual pumpkins! WHAT?! Yep, it’s not technically pumpkin that’s in the cans of 100% pure pumpkin! FRAUD! Well, actually no! So, here is what is the deal. The FDA does not give distinctions as to the difference among the varieties of most pumpkins, squash, and gourds because of their very close genetic makeup. Therefore companies are not violating any laws about the contents. See FDA’s notes->



CPG Sec. 585.725 “Pumpkin” - Labeling Articles Made from Certain Varieties of Squash

BACKGROUND:

Canned “pumpkin” has for many years been packed from field pumpkin (*Cucurbita pepo*) or certain varieties of firm-shelled, golden-fleshed, sweet squash (*Cucurbita maxima*), or mixtures of these. Pumpkin and squash are sometimes mixed intentionally to obtain the consistency most acceptable to users.

Since 1938, we have consistently advised canners that we would not initiate regulatory action solely because of their using the designation “pumpkin” or “canned pumpkin” on labels for articles prepared from golden-fleshed, sweet squash, or mixtures of such squash with field pumpkins. In the absence of any evidence that this designation misleads or deceives consumers we see no reason to change this policy.

POLICY:

In the labeling of articles prepared from golden-fleshed, sweet squash or mixtures of such squash and field pumpkin, we will consider the designation “pumpkin” to be in essential compliance with the “common or usual name” requirements of sections 403(i)(1) and 403(i)(2) of the Federal Food, Drug, and Cosmetic Act, and the “specifying of identity” required by section 1453(a)(1) of the Fair Packaging and Labeling Act.

Issued: 6/20/69

Revised: 8/20/73

Reissued: 10/1/80, 12/8/88

<http://www.fda.gov/ICECI/ComplianceManuals/CompliancePolicyGuidanceManual/ucm074635.htm>

Perfectly Timed Cat Photos

If you spend enough time on the internet and especially on Facebook, you undoubtedly have come across all sorts of mini stories with photos that you have to click page by page to view. In addition, a large majority of those posts are of animals and especially cats. Here is a selection of so called "perfectly timed" photos involving cats. Enjoy!

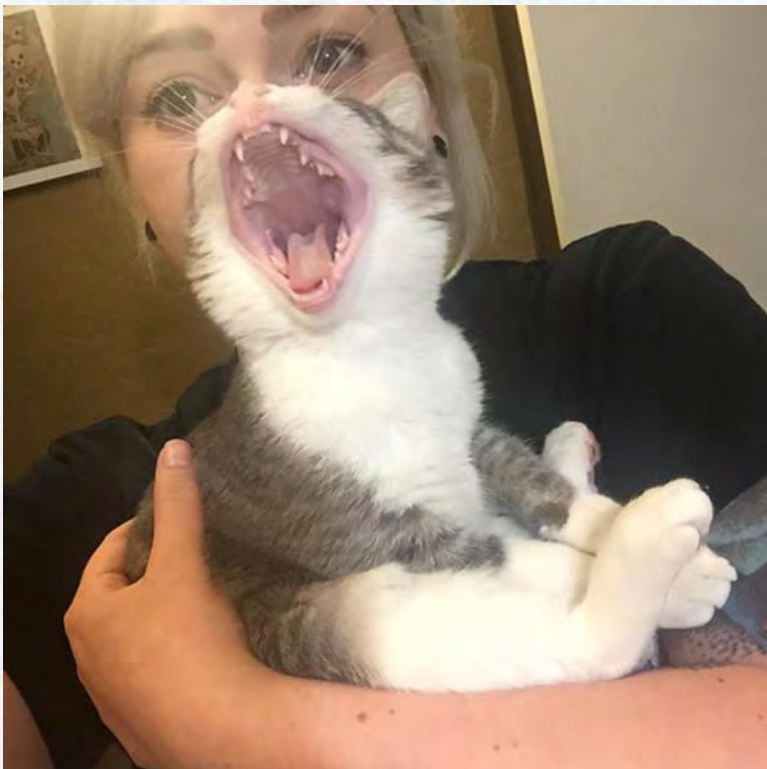

Historical Archives

Carbonate Chronicle [Leadville, Colorado], December 20, 1879.

A BAD BRONCHO.

His Kick Seriously Demoralizes
William Lutridge.

In some of our stables is to be found the generally vicious and untamable species of horse flesh known to fame as the broncho. There is one at Wall & Witter's which justifies all the hard things said about those animals by his appearance and actions. This animal hates the entire human race and uses every opportunity for showing this hatred by biting, kicking, etc. This morning it seemed to be in a particularly vicious mood, and when William Lutridge, an employee at the stable, incautiously approached too close to the brute's heels, it let fly and knocked him clear across the stable. Those who saw the occurrence, expected to find only a mass of blood, bones and mince-meat, but it proved not quite so bad as that. Dr. Hewitt was promptly called to the aide of poor Lutridge, and the doctor states that he will probably live, although the bone of his right leg is broken in two places, he has a serious

scalp wound, and has also suffered concussion of the brain.

Lutridge was conveyed to the Sisters' hospital, where he will be tenderly cared for.

A BAD BRONCHO.

His Kick Seriously Demoralizes
William Lutridge.

In some of our stables is to be found the generally vicious and untamable species of horse flesh known to fame as the broncho. There is one at Wall & Witter's which justifies all the hard things said about those animals by his appearance and actions. This animal hates the entire human race and uses every opportunity for showing this hatred by biting, kicking, etc. This morning it seemed to be in a particularly vicious mood, and when William Lutridge, an employee at the stable, incautiously approached too close to the brute's heels, it let fly and knocked him clear across the stable. Those who saw the occurrence, expected to find only a mass of blood, bones, and mince-meat, but it proved not quite so bad as that. Dr. Hewitt was promptly called to the aide of poor Lutridge, and the doctor [says] that he will probably live, although the bone of his right leg is broken in two places, he has a serious

scalp wound, and has also suffered concussion of the brain.

Lutridge was conveyed to the Sister's hospital, where he will be tenderly cared for.

Many Mile Markers in 2016

2016 has proved to be a year of milestones for me for different things I've done. Here are a few of them.

- ◆ 1986, 30 years since starting junior high (actually in fall 1985)
- ◆ 1991, 25 years since graduating high school
- ◆ 1991, first year in college (in this case, community college)
- ◆ 1996, Moved to Flagstaff, Arizona
- ◆ 1996, Started college at Northern Arizona University
- ◆ 2001, Moved to Lubbock, Texas
- ◆ 2001, Started college at Texas Tech University
- ◆ 2006, Started working at the National Ranching Heritage Center
- ◆ 2011, Started the sole proprietorship, Top Hand Graphics

100 Years of the Forest Service

The centennial of the National Park Service was on August 25, 2016. Now while the NPS started in 1916, its roots go back to even 1872 when President Grant signed into law the Yellowstone National Park, the first national park. After that, several other parks were created including Yosemite in 1890, Sequoia in 1890, Mount Rainier in 1899, Crater Lake in 1902, Wind Cave in 1903, Mesa Verde in 1906, Glacier in 1910, and Rocky Mountain in 1915. In addition, President Roosevelt

signed into law the Antiquities Act to protect and designate as national monuments locations like prehistoric cliff dwellings, pueblo ruins, and early missions in the Southwest along with authorizing future presidents to proclaim and preserve "historic landmarks, historic and prehistoric structures, and other objects of historic or scientific interest" on lands owned or controlled by the United States as "national monuments". With all these parks operating individually under the Department of the Interior, needless to say that support was probably fragmented. Wikipedia adds "Stephen Mather [and others] ran a publicity campaign for the Department of the Interior" and wrote "numerous articles that praised the scenic and historic qualities of the parks and their possibilities for educational, inspirational, and recreational benefits. On August 25, 1916, President Wilson signed a bill that mandated the agency 'to conserve the scenery and the natural and historic objects and wildlife therein, and to provide for the enjoyment of the same in such manner and by such means as will leave them unimpaired for the enjoyment of future generations.' Mather became the first director of the newly formed NPS." www.100yearsofnps.com

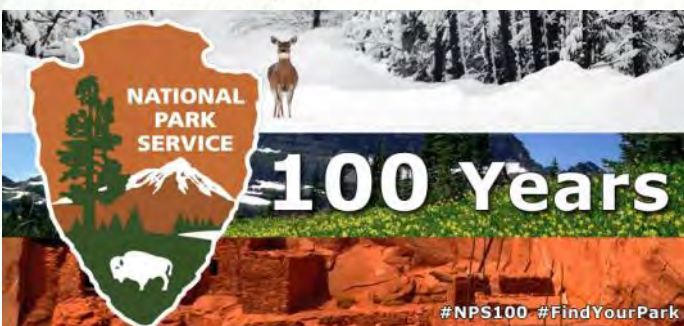

Did Not Exist 10 Years Ago

Ten years ago, we did not have many things that we now use regularly everyday or was still so new that most people did not use them. Here is a list.

Did not yet exist

- iPhone (2007)
- "smart phone"*
- iPad (2010)
- "social media"**
- Twitter (2006)
- 3d printers (early 2010s)
- cloud storage (mid 2000s)

Still very new

- Most social media sites
- YouTube (2005)
- Facebook (2004)
- Google Maps (2005)
- Flash drives (early 2000s)
- Wi-Fi Hotspot

**The first actual use of the term was in 1994, but with the advent of the iPhone is when the term really became widely used.*

***Just in the modern context.*



100 Years of Beauty—More Videos

https://www.youtube.com/playlist?list=PLJic7bfGlo3qlgmccaaNAXTChp_Ny8CE4

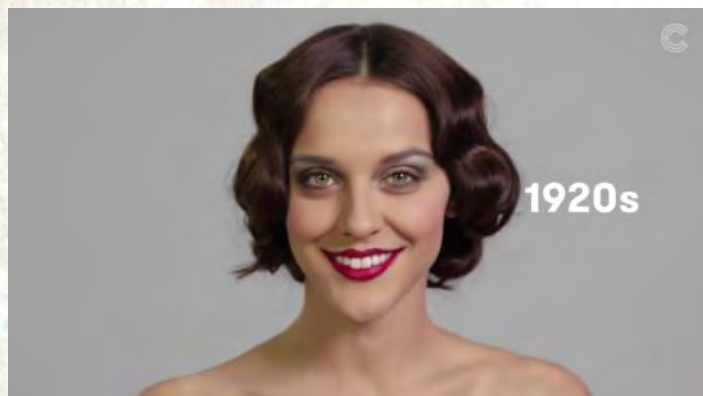

Argentina—1920s

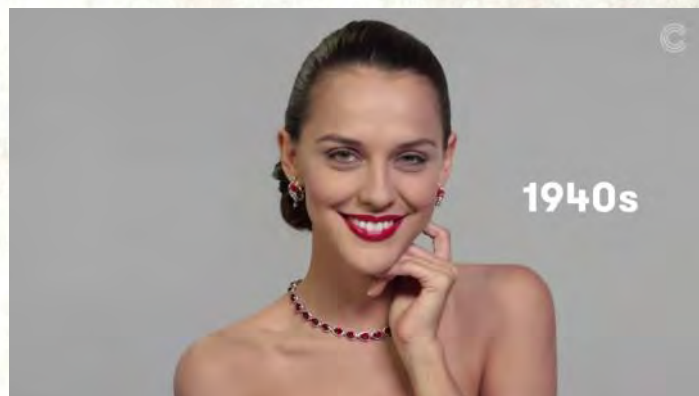

Argentina—1940s



Argentina—1980s



Argentina—2000s

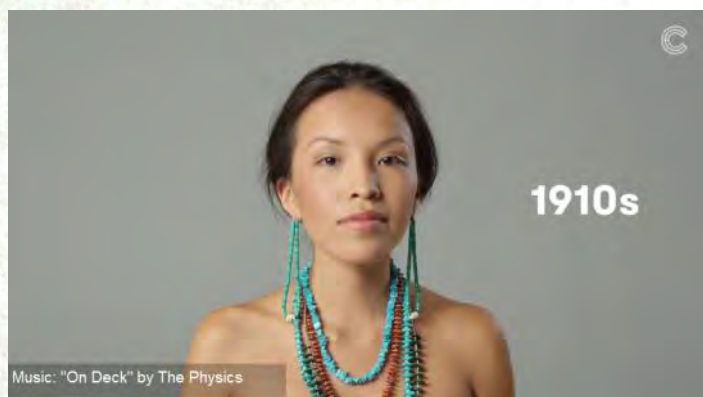

Navajo (Diné)—1910s

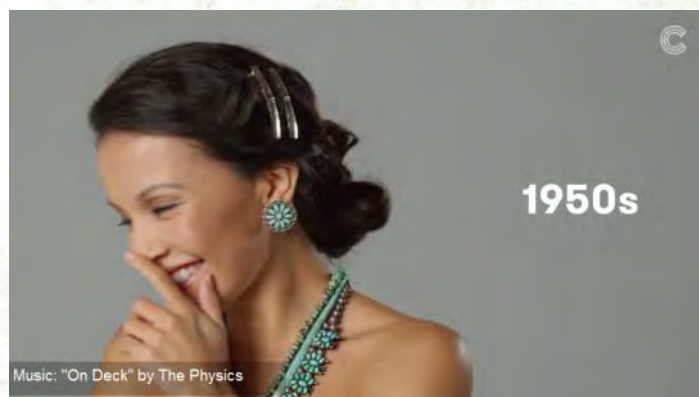

Navajo (Diné)—1950s

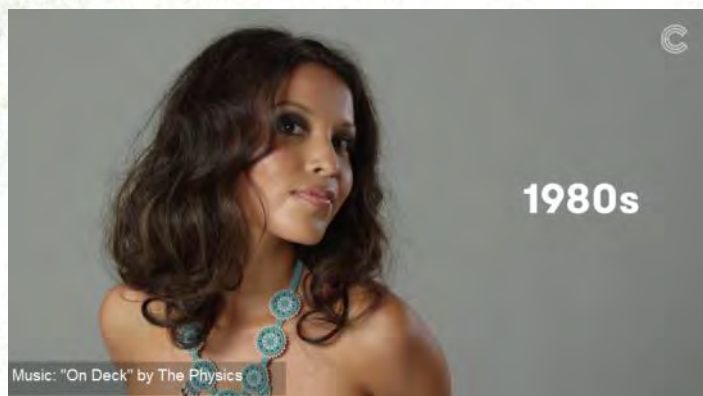

Navajo (Diné)—1980s

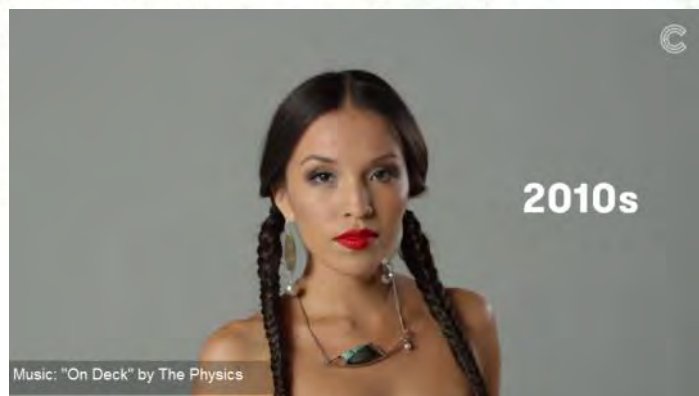

Navajo (Diné)—2010s

100 Years of Beauty—More Videos

https://www.youtube.com/playlist?list=PLJic7bfGlo3qIgmccaaNAXTChp_Ny8CE4

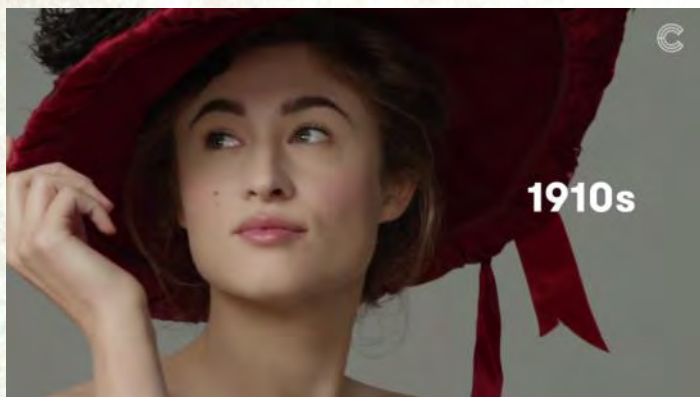

France—1910s



France—1920s



France—1940s

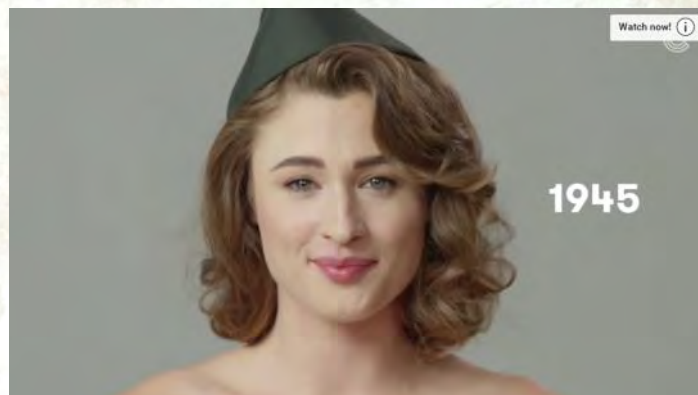

France—1945

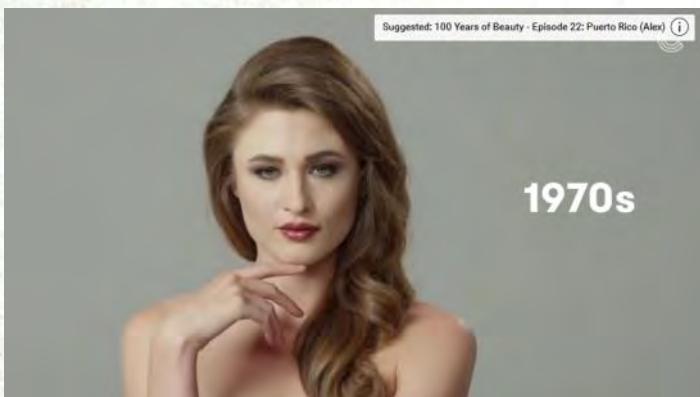

France—1970s

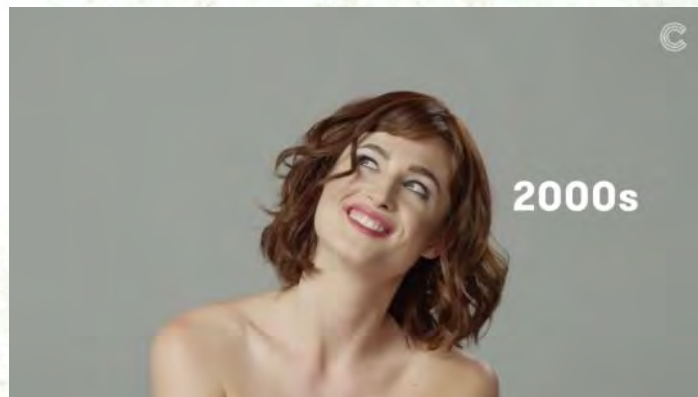

France—2000s

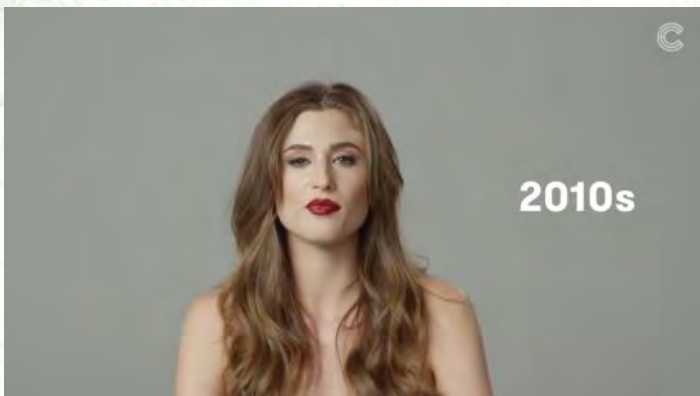

France—2010s

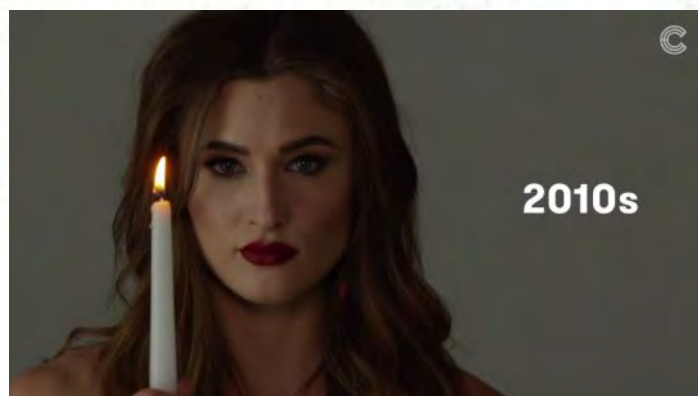

France—2016 (Post attacks)

Lubbock's Carpenter Gothic— St. Paul's-On-The-Plains Church

In Lubbock, a Carpenter Gothic structure exists that has been here for over 100 years. This structure is an Episcopal church called St. Paul's-On-The-Plains. It's current location is in its third spot from the time it was built in 1914. The structure has a history that mirrors that of Temple Israel in Leadville in that it was a religious structure, sat empty, and used as housing, then restored. There is much to say about the history of this little building, and take a look at the following links to read more about it, but an interesting story told about the building is:

"The first tiny St. Paul's Church was heated by a wood-and-coal burning stove and the men in the congregation took turns stoking the fire during the service. The members who sat away from the stove froze in the wintertime and those closest to the stove fainted. At Easter it was not considered a successful service unless at some time someone would faint from the heat and had to be carried out."

The building today is located at K.N. Clapp Park and operated by the Lubbock Garden and Arts Center. The building is available for rent to use for weddings, meetings, receptions, etc. Also, the Lubbock Memorial Arboretum is located adjacent to the park.

www.stpaulslubbock.org/index.php/about-us/history

www.lubbockheritagesociety.bravehost.com/LHS_stpauls.html

www.lubbockarboretum.org/index.php/plan-a-visit/st-paul-of-the-plains-chapel



"Episcopal Church Lubbock, Tex.," "Photo by E. Brown" 1910s? 1920s?

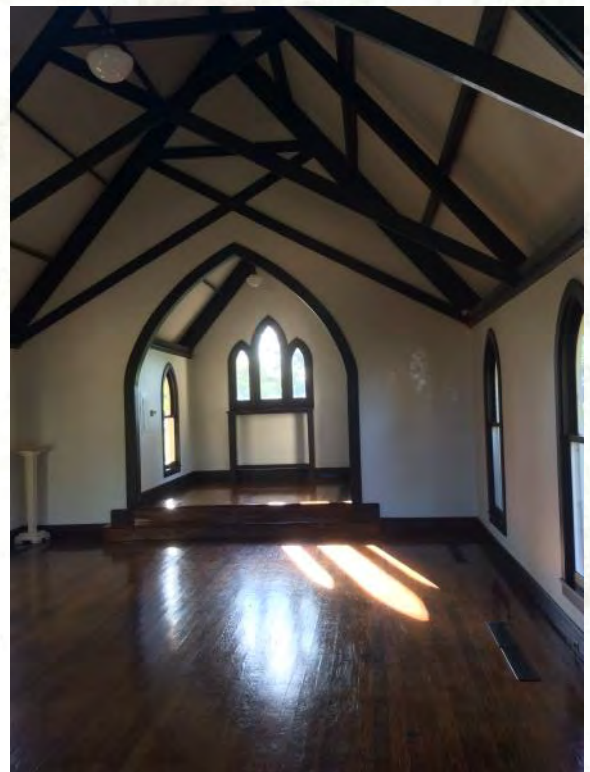

100 Years of Home Innovation

PRESENTED BY **dyson**

100 YEARS OF HOME INNOVATION

MODE



100 Years of Home Innovation

1920s



1930s



100 Years of Home Innovation



100 Years of Home Innovation



100 Years of Home Innovation



100 Years of Home Innovation



Equine Judging: What Does It All Mean

If you are even a little bit into horses, meaning that you are around them or have one (or two, or three, or ten...), then you are probably aware of the equine show ring. Well, judges take notes during the

exhibitions with scribbles and shorthand that might leave you wondering what it means. Well, here are a few ideas of what some of them can mean! :-P www.chronofhorse.com/article/judges-card-original-emojis

	Round jump		Flyer at vertical		Need bigger coffee
	Flat Jump		Flyer at Oxer		Mare
	Inverted Jump		I am so posting this round on YouTube		Gelding
	He's jumping! No he's not...yes he is...no he's not...oooh crap!!!		Horse too thin. Please give him more food!		Stallion
	Chip		Okay, that's enough.		Good position
	Chocolate Chip		Need coffee		Poor position
	Rail		What was that? Seriously, WTF was that?		No-Point position
	More Rails		Stepped in water		Coffee not working anymore
	Clean up on aisle six		Tempi changes not advised in hunter class		White pony
	Too much whip		Too much bling		Another white pony
	Too much neigh neigh		Sped up		And another one
	Refusal		Slowed down		Exactly how many white ponies are there???
	Refusal with impressive skid marks		Sped up and then slowed down		Seriously, is there some kind of white pony factory?
	Drive-by		Oops, sneezed. Sorry		OH, COME ON!!!
	Horse attentive		Moves good		Finally! A brown one
	Horse Inattentive		Moves great		Great, now they're all brown
	Opening circle too big		Moves like Jagger		
	Opening circle too small				
	Now all I can think about is donuts				

WORD SEARCH

E S T R R T E N D E R S
E E A S R A T I U G N B
E L E L A W O T L N L T
T F A I R O I T T U S L
A F A M E I T N E N F L
L A N S R I R S G C S L
P W T A I I O S A S E C
M E A U U O O P C X S A
I N E C A S E I R F E U
L E A E D S T L A N L T
S N E K C I H C M I L S
E S A E A T L E D N W L

WORD KEY:

- DELTA
- FRIES
- WINGS
- BLUES
- TENDERS
- GUITAR
- WAFFLES
- SLIM PLATE
- SLIM SAUCE
- SLIM CHICKENS
- TEXAS TOAST

WORD SEARCH

E S T R R T E N D E R S
E E A S R A T I U G N B
E L E L A W O T L N L T
T F A I R O I T T U S L
A F A M E I T N E N F L
L A N S R I R S G C S L
P W T A I I O S A S E C
M E A U U O O P C X S A
I N E C A S E I R F E U
L E A E D S T L A N L T
S N E K C I H C M I L S
E S A E A T L E D N W L

WORD KEY:

- DELTA
- FRIES
- WINGS
- BLUES
- TENDERS
- GUITAR
- WAFFLES
- SLIM PLATE
- SLIM SAUCE
- SLIM CHICKENS
- TEXAS TOAST

Upcoming Issues

The next issue is the December 2016 issue (5.12).
Here's a preview of topics to come in future issues.

Public Art of Texas Tech University

Texas Tech University has a public art program where 1% of the budget of any new building or addition or remodel of a building must be dedicated to some sort of public art. Over by the Bayer Crop Science buildings (which is over behind the National Ranching Heritage Center), the public art there are these very unusual but fun street lights!



Texas Jack

In past issues, I showed you the grave of John Baker Omohundro, but you know him better as Texas Jack. He died in 1880 and is buried in the Evergreen Cemetery in Leadville, Colorado. I'll tell you more about him.



Route 66

The Mother Road was well known in the early 1900s after cars became a standard mode of transportation. Travelling became easier and more common. Learn more about this famous road.



XIT Ranch

What does the XIT Ranch in the Texas Panhandle have to do with the state Capitol building in Austin over 500 miles away? Learn some basic facts and see some interesting photos of this famous ranch that was sort of an afterthought at the turn of the century.

de Stolfe Journal Candid • 2102 W Loop 289 Apt 194 • Lubbock, Texas 79407

RG de Stolfe
806.470.5867
rgdestolfe@yahoo.com

